

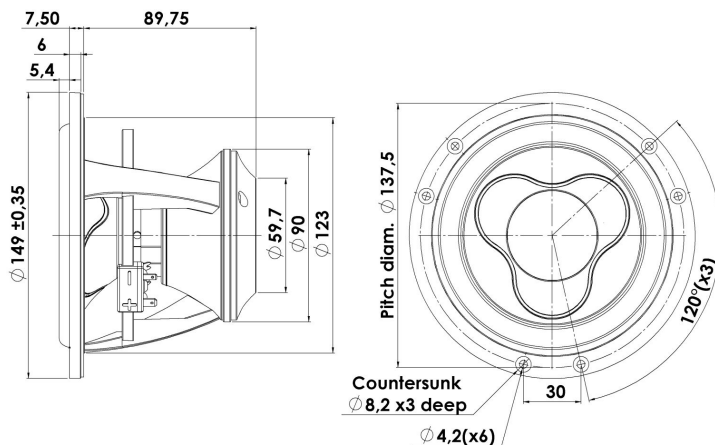

MIDWOOFER

15WU/8741T00

The Illuminator midranges and midwoofers are in every aspect unusual designs with the open construction, the extremely long linear excursion and patented under-hung SD-3 (Symmetrical Drive) neodymium motor system, which due to copper caps and its construction ensures very low distortion, adding the unique patented cones, low-loss linear suspension the result is: "The Very Best Money Can Buy"!



KEY FEATURES:

- Under-Hung Neodymium Motor Design
- Patented Sandwich Paper Cone
- Low-loss linear suspension
- Patented Symmetrical Drive (SD-3)
- Exceptionally Long Linear Excursion
- Patented Design

T-S Parameters

Resonance frequency [fs]	35 Hz
Mechanical Q factor [Qms]	3.37
Electrical Q factor [Qes]	0.28
Total Q factor [Qts]	0.26
Force factor [Bl]	7.5 Tm
Mechanical resistance [Rms]	0.80 kg/s
Moving mass [Mms]	12.3 g
Compliance [Cms]	1.68 mm/N
Effective diaph. diameter [D]	108 mm
Effective piston area [Sd]	92 cm ²
Equivalent volume [Vas]	19.9 l
Sensitivity (2.83V/1m)	83.4 dB
Ratio Bl/√Re	3.09 N/√W
Ratio fs/Qts	135 Hz

Notes:

IEC specs. refer to IEC 60268-5 third edition.
All Scan-Speak products are RoHS compliant.
Data are subject to change without notice.
Datasheet updated: January 30, 2013.

Electrical Data

Nominal impedance [Zn]	8 Ω
Minimum impedance [Zmin]	7.9 Ω
Maximum impedance [Zo]	76.9 Ω
DC resistance [Re]	5.9 Ω
Voice coil inductance [Le]	0.41 mH

Power Handling

100h RMS noise test (IEC 17.1)	80 W
Long-term max power (IEC 17.3)	150 W

Voice Coil & Magnet Data

Voice coil diameter	42 mm
Voice coil height	8 mm
Voice coil layers	4
Height of gap	20 mm
Linear excursion	± 9 mm
Max mech. excursion	± 13 mm
Unit weight	1.7 kg



MIDWOOFER

15WU/8741T00

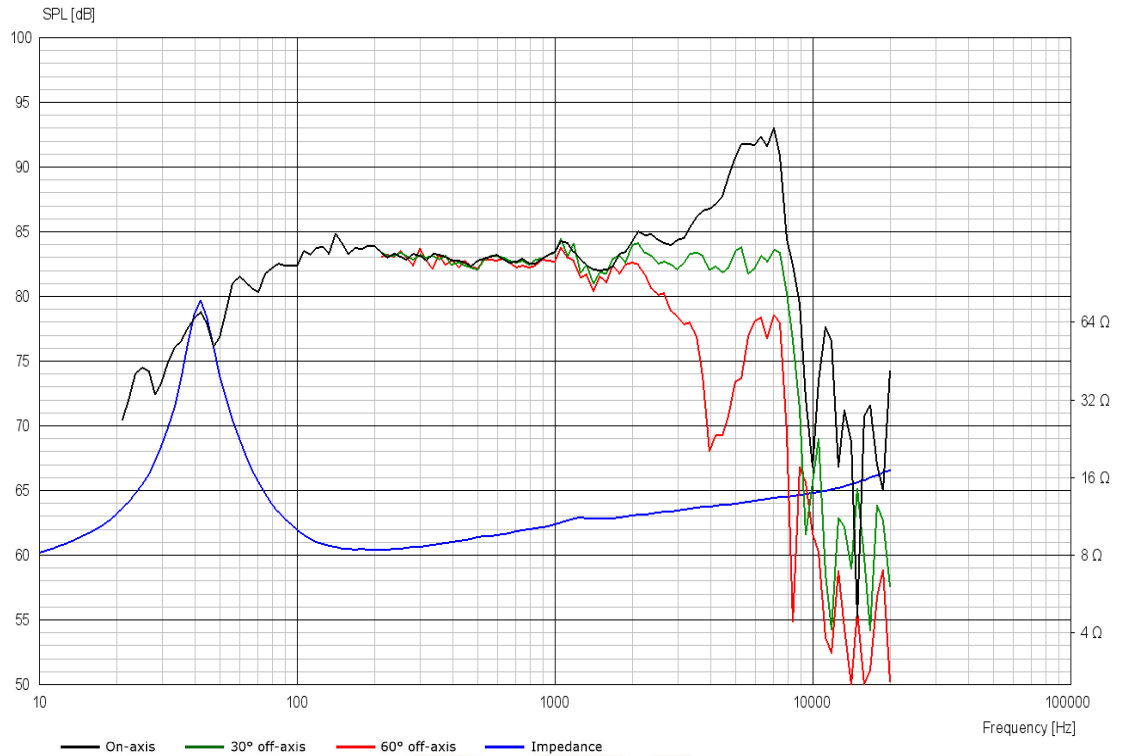

Advanced Parameters (Preliminary)

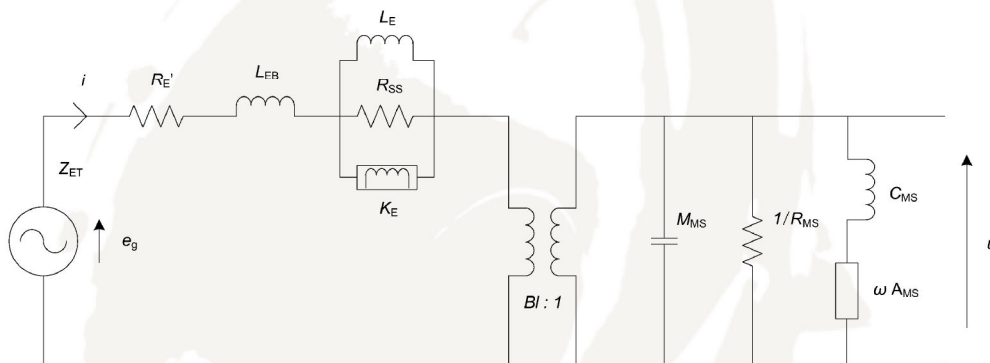

Electrical data

Resistance [$R_{E'}$]	6.42 Ω
Free inductance [L_{EB}]	0.080 mH
Bound inductance [L_E]	6.49 mH
Semi-inductance [K_E]	0.130 SH
Shunt resistance [R_{SS}]	8 Ω

Mechanical Data

Force Factor [Bl]	7.39 Tm
Moving mass [M_{MS}]	14.1 g
Compliance [C_{MS}]	1.34 mm/N
Mechanical resistance [R_{MS}]	0.79 kg/s
Admittance [A_{MS}]	0.23 mm/N